

# FIREPLACE/WOOD STOVE

**TRADITIONAL FIREPLACE** – The fire burns in a metal firebox lined with firebrick. The heat creates a draft that pulls smoke up through the throat to a **smoke chamber** then up the flue, which is usually a tile or metal liner inside a masonry chimney. A **flue damper** regulates the draft and keeps air from escaping up the flue when the fireplace is not in use. The **smoke shelf** behind the damper stops backdrafts of outside air that could push smoke into the living area. Most draw air from inside the house – a grate holds the logs so that air can stoke the fire from underneath – while others draw air from the outside through an air intake. An intake damper seals the intake when the fireplace is not in use.

A **heat-circulating fireplace** produces some radiant heat, but mainly warms air that circulates around the firebox. Some have a fan that increases the air flow. They achieve a high efficiency by enclosing the fireplace with glass doors and are equipped with an outside air intake.

**GAS FIREPLACE** – This type of unit is mostly decorative. Gas logs should be used in a fireplace only designed to burn wood and should be operated with the damper always open so carbon monoxide will vent up the chimney. A **Direct-vent** fireplace is like a wood-burning heat circulator – cool air enters at the bottom, is warmed, and rises out the vent at the top; the CO is expelled out the rear so there is no need of a chimney

**FIREPLACE INSERT** – These units operate more like a wood stove and fit into an existing fireplace. They operate at efficiency levels of **30 to 50%** compared to a traditional fireplace. The space around the unit must be covered with sheet steel plate and sealed with a cement grout or mortar. A flue liner must extend from the unit through the top of the chimney. This improves the draft, keeps the gases hotter (which reduces creosote building and reduces the risk of flue gases seeping back into the house.

**WOOD STOVE** – A modern wood stove is more efficient than a heat-circulating fireplace. Some only radiate heat while others also heat air passing around the firebox in convection currents. **Advanced systems** create conditions to burn combustible gases without the use of catalysts. With **catalyst stoves**, a catalytic combustor (a ceramic honeycomb) extracts heat from flue gases. **Pellet stoves** use manufactured pellets that are fed into the combustion chamber by a timed screw auger. Wood stoves must sit on a non-combustible hearth which must extend a least eight inches beyond the sides and back and **18 inches in front** of it and be at least **24 inches from side walls** and **30 inches from back wall** (check with your local building or fire codes.) Only black steel stovepipe (24 gauge min.) should be used between a wood stove and chimney. The overall run of stove pipe should be under 10 feet with no more than two 90° elbows.

## **MAINTENANCE ITEMS FOR SERVICE TECHNICIAN:**

- **CLEAN THE CHIMNEY** – creosote can start fires, crack masonry and loosen stovepipe sections; chimney should be cleaned when creosote buildup reaches  $\frac{1}{8}$  inch thickness
- **FIREBOX AND MASONRY REPAIRS** – any cracks wider than  $\frac{1}{64}$  inch pose a fire hazard and should be filled with refractory masonry; repoint masonry joints and replace broken bricks

## **SAFETY TIPS:**

- **DO NOT BURN TRASH; CHRISTMAS TREES/WRAPPING OR CHARCOAL IN A WOOD-BURNING UNIT**
- **DO NOT BURN PRESSURE-TREATED OR PAINTED WOOD – IT CAN PRODUCE DANGEROUS FUMES**
- **DO NOT BURN PINE OR SOFT WOOD, WHICH CAN CAUSE RAPID CREOSOTE BUILDUP**
- **NEVER OVERLOAD A FIREPLACE OR WOOD STOVE – THIS CAN REDUCE AIR FLOW AND COMBUSTION**
- **REMOVE ASHES – AN ASH PIT MAY NEED TO BE CLEANED ONLY ONCE A YEAR; A STOVE WILL PERFORM BETTER IF A ONE TO TWO INCH LAYER IS LEFT OVER THE GRATES**
- **OLD CHIMNEYS SHOULD BE LINED WITH TILE OR METAL (ONES BUILT BEFORE 1950 DO NOT HAVE LINERS)**
- **PURCHASE ONLY DIRECT-VENT FIREPLACES RATED BY UNDERWRITERS' LABORATORIES (UL); THE AMERICAN GAS ASSOCIATION AGA OR THE CANADIAN GAS ASSOCIATION (CGA)**

For further information contact your local public utilities office, fire department, a licensed HVAC contractor or the American Society of Heating, Refrigerating and Air-conditioning Engineers (ASHRAE).

# FIREPLACE/WOOD STOVE

## CHARACTERISTICS OF WOODS USED IN A FIREPLACE OR WOOD STOVE

SPECIES	EASE OF STARTING	EMBER GENERATION	SPARKS	HEATING VALUE	FRAGRANCE
Apple	Poor	Excellent	Few	Good	Excellent
Ash	Fair	Good	Few	Good	Slight
Beech	Poor	Good	Few	Excellent	Slight
Birch (white)	Good	Good	Moderate	Good	Slight
Cherry	Poor	Excellent	Few	Good	Excellent
Cedar	Excellent	Poor	Many	Fair	Good
Elm	Fair	Good	Very few	Good	Fair
Hemlock	Good	Low	Many	Fair	Good
Hickory	Fair	Excellent	Moderate	Excellent	Slight
Locust (black)	Poor	Excellent	Very few	Excellent	Slight
Maple (sugar)	Poor	Excellent	Few	Excellent	Good

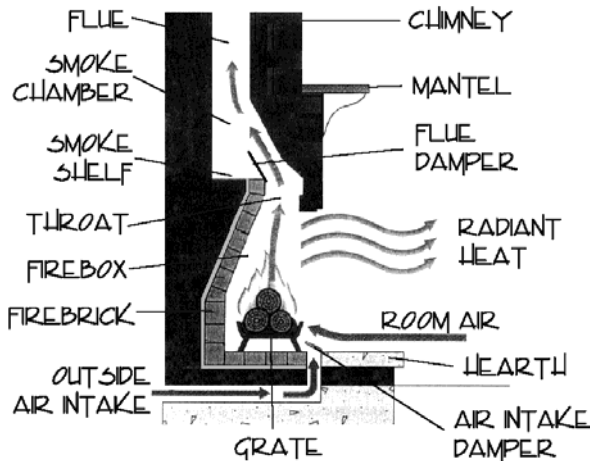

**TYPICAL WOOD FIREPLACE**

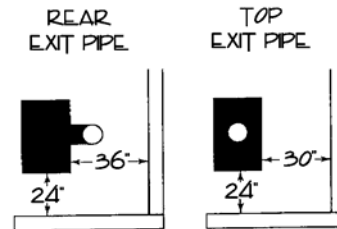

CHECK LOCAL CODES AND MANUFACTURER'S SPECIFICATIONS

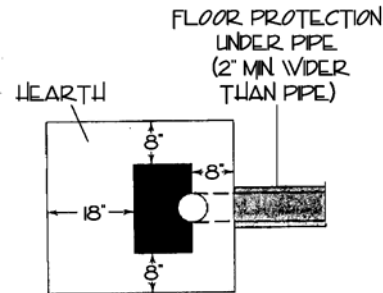

**TYPICAL WOOD STOVE LOCATION FROM WALLS AND TYPICAL HEARTH SPECIFICATIONS**

**TYPICAL PELLET WOOD STOVE**

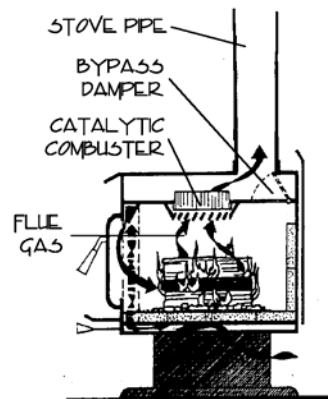
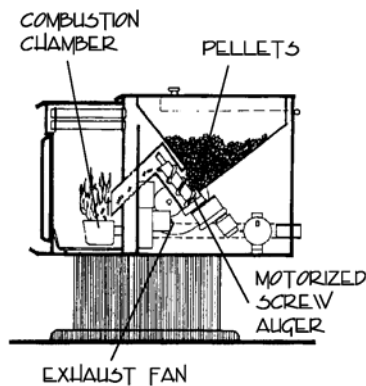

**TYPICAL CATALYST WOOD STOVE**