

# GFCI PROTECTION

A ground fault circuit interrupter (GFCI) is an electrical device, either a receptacle or circuit breaker, which is designed to protect people from electric shock in a wet or damp environment. GFCI protection should not be confused with grounding. Even if a system is properly grounded, minor faults in a circuit can cause a dangerous shock to a person using an appliance in a damp location or near water.

The GFCI senses the flow of electricity through a circuit. If more current is flowing through the **black**, or **hot** wire than the **white** or **neutral** wire, there is a current leakage (a "ground fault"). The GFCI can detect a leakage as little as **five thousands of an amp** (.005 amps), which will shut off the current in  $\frac{1}{40}$  of a second to prevent injury.

## **WHERE TO LOOK FOR GFCI PROTECTION:**

- ALL OUTDOOR RECEPTACLES THAT ARE WITHIN SIX FEET OF THE GROUND
- RECEPTACLES AT HOT TUBS, SPAS AND AROUND SWIMMING POOLS
- RECEPTACLES AND SUPPLIES FOR FOUNTAIN OR POOL PUMPS AND RELATED EQUIPMENT
- ALL BATHROOM RECEPTACLES
- RECEPTACLES WITHIN SIX FEET OF THE KITCHEN SINK, WET BARS AND LAUNDRY TUBS
- AT LEAST ONE RECEPTACLE IN THE BASEMENT AND CRAWL SPACES
- ALL RECEPTACLES IN THE GARAGE (EXCEPT ONE MARKED FOR FREEZER)
- ALL LIGHTING IN HIGH-RISK AREAS SUCH AS WET BARS, BATHTUBS, SPAS, SAUNAS, OR SHOWERS

If you have GFCI receptacles, it is recommended that you test (and reset) them monthly. On a GFCI receptacle when you push the TEST button, the RESET button should pop out, hence shutting off the circuit. Or you can use a **GFCI tester/analyzer**, available at most hardware stores to perform the same test. There is a button on the **tester/analyzer** that should trip the circuit within a couple of seconds and the RESET button should pop out.

The GFCI receptacle contains a resistor connecting the LOAD side of the hot wire to the LINE side of the neutral wire. When you press the TEST button, current through this resistor shows up as an imbalance and trips the GFCI. However, failure of the GFCI to trip in response to a **tester/analyzer** may or may not indicate a real defect. There may be an absence of ground, and the **tester/analyzer** does not trip the circuit. The absence of ground has no effect on the operation of the GFCI. The device should work if there is a *real* short to ground. That is why GFCI receptacles are also used in ungrounded circuits such as KNOB and TUBE wiring.

The same procedure should be done with a GFCI breaker. The GFCI will be located in the distribution or service panel. The breaker can be identified by a TEST button in addition to the breaker switch. Press the TEST button and the breaker switch should trip. Switch the breaker back to the ON position. Do this once a month – breakers have a tendency to stick, and may not protect you when needed.

If you have a GFCI breaker you should also use the **tester/analyzer** to test the receptacles in the vulnerable areas listed above. Note that the receptacle may appear like a normal receptacle without any TEST or RESET buttons, but may be protected in the circuit by the GFCI breaker. Remember to reset the breaker to the ON position after the **tester/analyzer** has tripped the breaker. It is mandatory that receptacles be label if protected by GFCI but ungrounded.

If a grounded GFCI does not trip with a **tester/analyzer**, or if an ungrounded GFCI receptacle does not trip with its own built in buttons, it is probably defective or miswired. Again, if the TEST button on the receptacle or breaker does not work, something is broken and potentially dangerous. The problem should be corrected immediately.

If your house does not have GFCI protection, an electrician can add it. This is an important safety improvement. Electrical wiring and device installation should be handled by a licensed electrician.

For further information contact your local public utilities office or a licensed electrician.

# GFCI PROTECTION

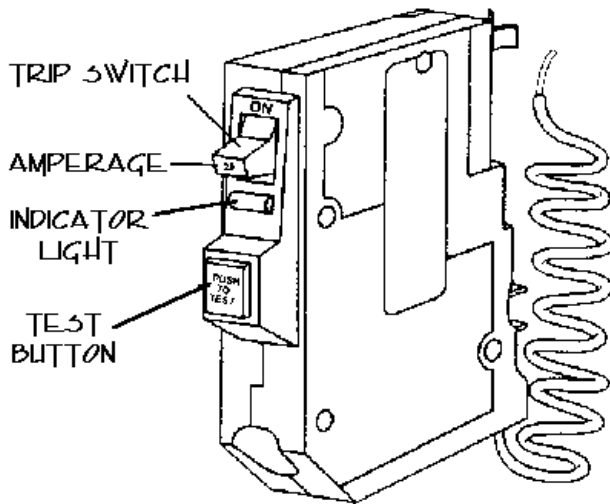

Ground Fault Circuit Interrupter (GFCI) breaker

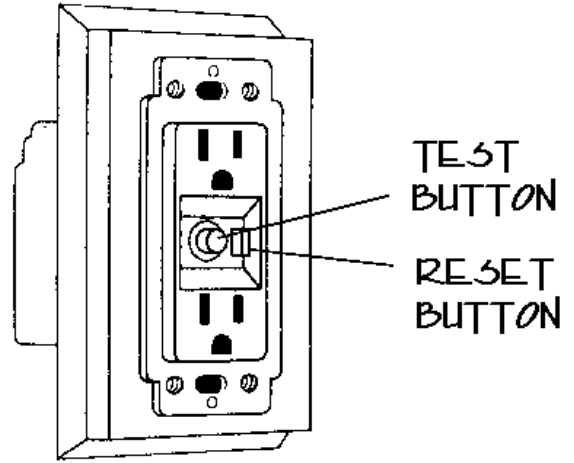

Ground Fault Circuit Interrupter (GFCI) receptacle

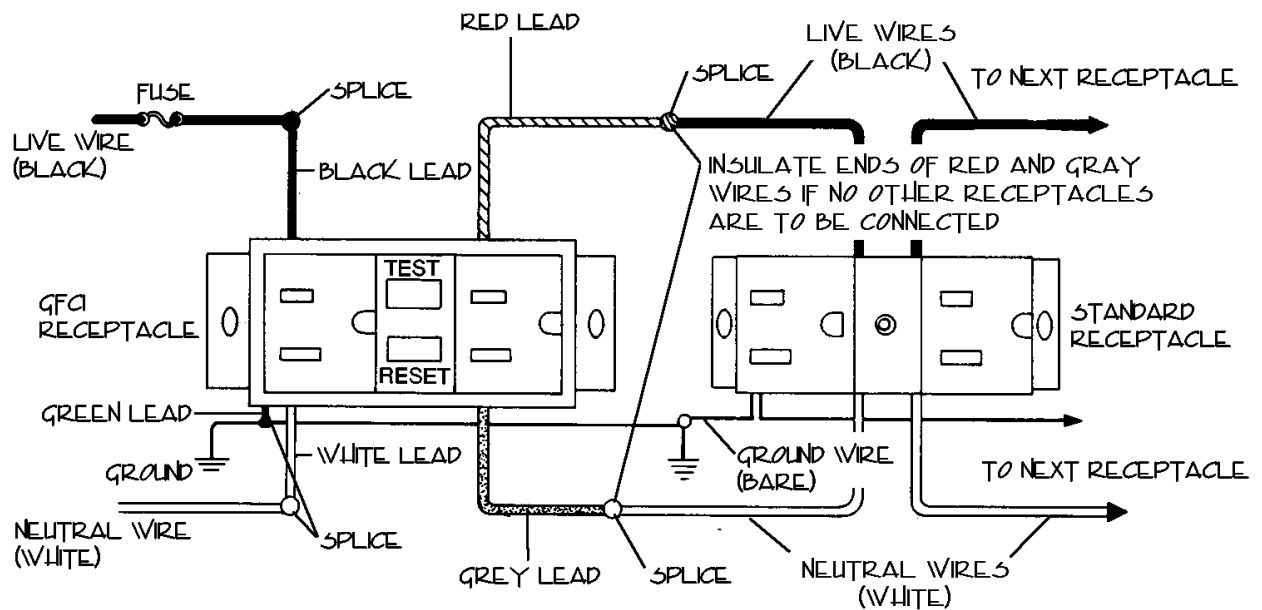

Typical connection for GFCI receptacle installation  
(one GFCI protective standard receptacle on same circuit)